

## Pump type GP-GPM 45EV-65EV

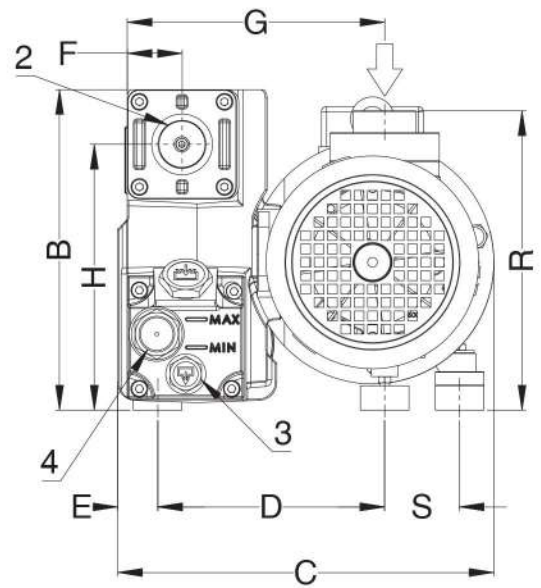

- 1 Suction
- 2 Discharge
- 3 Oil discharge plug
- 4 Oil sight glass
- 5 Oil fill up plug

|        | Dimension (mm) |     |     |     |    |    |     |     |     |     |     |    |     |    |
|--------|----------------|-----|-----|-----|----|----|-----|-----|-----|-----|-----|----|-----|----|
| GP-GPM | A              | B   | C   | D   | E  | F  | G   | H   | L   | M   | P   | Q  | R   | S  |
| 45EV   | 530            | 264 | 310 | 187 | 33 | 45 | 212 | 219 | 155 | 155 | 177 | 58 | 246 | 62 |
| 65EV   | 530            | 264 | 310 | 187 | 33 | 45 | 212 | 219 | 155 | 155 | 177 | 98 | 246 | 62 |

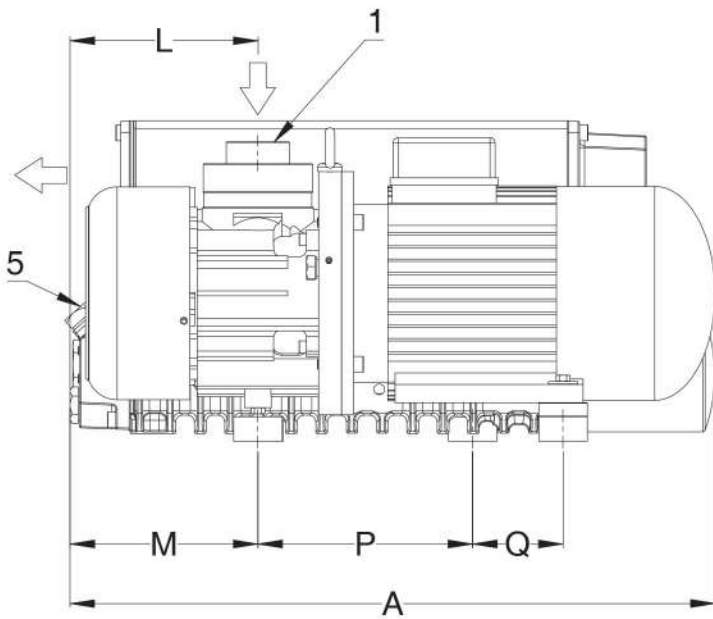